

**TESTING FOR THE VERIFICATION OF COMPLIANCE OF PV
INVERTER WITH:**

**IEC 60068-2-1, Environmental Testing. Part 2-1:
Tests. Test Ae: Cold.**

**IEC 60068-2-2, Environmental Testing. Part 2-2:
Tests. Test Be: Dry heat.**

**IEC 60068-2-14, Environmental Testing. Part 2-14:
Tests. Test Nb: Change of temperature.**

**IEC 60068-2-30, Environmental Testing. Part 2-30:
Tests. Test Db-Variant 1: Damp heat, cyclic (12 h + 12 h cycle).**

Procedure: PE.T-LE-62

Test Report Number: 2219 / 0185 -D-E1(*)

(*) *This report supersedes report 2219 / 0185 -D. For detailed information refer to page 7.*

Trademark



Tested Model: SOFAR 3300TL-G3

Variant Models: SOFAR 2700TL-G3, SOFAR 2200TL-G3,
SOFAR 1600TL-G3, SOFAR 1100TL-G3,
SOFAR 3000TL-G3.

APPLICANT

Name: Shenzhen SOFAR SOLAR Co., Ltd.

Address: 401, Building 4, AnTongDa Industrial Park, District 68,
XingDong Community, XinAn Street, BaoAn District, Shenzhen
City, Guangdong Province, P.R. China

TESTING LABORATORY

Name: SGS Tecnos, S. A. (Electrical Testing Laboratory)

Address: C/ Trespaderne, 29 - Edificio Barajas 1
28042 MADRID (Spain)

Conducted (tested) by: Hugo Zhang

(Project Engineer)

Roger Hu

(Project Engineer)

Approved by: Jacobo Tevar
(Technical Reviewer)

Date of issue: 26/07/2019

Number of pages: 29

Important Note:

- This document is issued by the Company subject to its General Conditions of Service printed overleaf, available on request or accessible at www.sgs.com/terms_and_conditions.htm and, for electronic format documents, subject to Terms and Conditions for Electronic Documents at www.sgs.com/terms_e-document.htm. Attention is drawn to the limitation of liability, indemnification and jurisdiction issues defined therein. Any holder of this document is advised that information contained hereon reflects the Company's findings at the time of its intervention only and within the limits of Client's instructions, if any. The Company's sole responsibility is to its Client and this document does not exonerate parties to a transaction from exercising all their rights and obligations under the transaction documents.
- This document cannot be reproduced except in full, without prior written approval of the Company. Any unauthorized alteration, forgery or falsification of the content or appearance of this document is unlawful and offenders may be prosecuted to the fullest extent of the law. Unless otherwise stated the results shown in this test report refer only to the sample(s) tested.

Test Report Historical Revision:

Test Report Version	Date	Resume
2219 / 0185	13/06/2019	First issuance
2219 / 0185 -D-E1	26/07/2019	This report is a modification of report 2219/0185-D for the inclusion of a new variant model SOFAR 3000TL-G3. See further information in page 7.

INDEX

1	SCOPE	4
2	GENERAL INFORMATION.....	5
2.1	Testing Period and Climatic conditions	5
2.2	Equipment under Testing	5
2.3	Test equipment list	8
2.4	Measurement uncertainty.....	8
2.5	Test set up of the different standard	9
2.6	Definitions.....	10
3	RESUME OF TEST RESULTS.....	11
4	TEST RESULTS	12
4.1	Test Ae: Cold.....	12
4.2	Test Be: Dry heat	13
4.3	Test Nb: Change of temperature.....	14
4.4	Test Db: Damp heat, Cyclic (12 h + 12 h)	16
5	PICTURES.....	18
6	ELECTRICAL SCHEMES.....	29

1 SCOPE

SGS Tecnos, S.A. (Electrical Testing Laboratory) has been contracted by Shenzhen SOFAR SOLAR Co., Ltd., in order to perform the testing according to the following Standards:

- IEC 60068-2-1:2007, Environmental Testing. Part 2-1: Tests. Test Ae: Cold.
- IEC 60068-2-2:2007, Environmental Testing. Part 2-2: Tests. Test Be: Dry heat.
- IEC 60068-2-14:2009, Environmental Testing. Part 2-14: Tests. Test Nb: Changes of temperature.
- IEC 60068-2-30:2005, Environmental Testing. Part 2-30: Tests. Test Db – Variant 1: Damp heat, cyclic (12 h + 12 h).

2 GENERAL INFORMATION

2.1 Testing Period and Climatic conditions

The necessary testing has been performed along between the 16th of May and 25th of May of 2019. Laboratory ambient temperature tests and checks have been performed at 25 ± 5°C, 96 kPa ± 10 kPa and 50% RH ± 10% RH.

SITE TEST

Name.....: Shenzhen SOFAR SOLAR Co., Ltd.
 Address.....: 401, Building 4, AnTongDa Industrial Park, District 68, XingDong Community, XinAn Street, BaoAn District, Shenzhen City, Guangdong Province, P.R. China

2.2 Equipment under Testing

Apparatus type.....: Solar Grid-tied Inverter (Single Phase Inverter)
 Installation.....: Fixed (permanent connection)
 Manufacturer.....: Shenzhen SOFAR SOLAR Co., Ltd.
 Trade mark.....: 
 Model / Type reference.....: SOFAR 3300TL-G3
 Serial Number.....: SA3ES033K4P001
 Software Version.....: V100
 Rated Characteristics.....: **DC input:** 50-550V Max.12A
AC output: 230Vac, 50Hz, Max.16A, 3300VA

Date of manufacturing: 2017

Test item particulars

Input.....: DC
 Output.....: AC
 Class of protection against electric shock...: Class I
 Degree of protection against moisture.....: IP 65
 Type of connection to the main supply.....: TN
 Cooling group.....: Heat sink
 Modular.....: No
 Internal Transformer.....: No

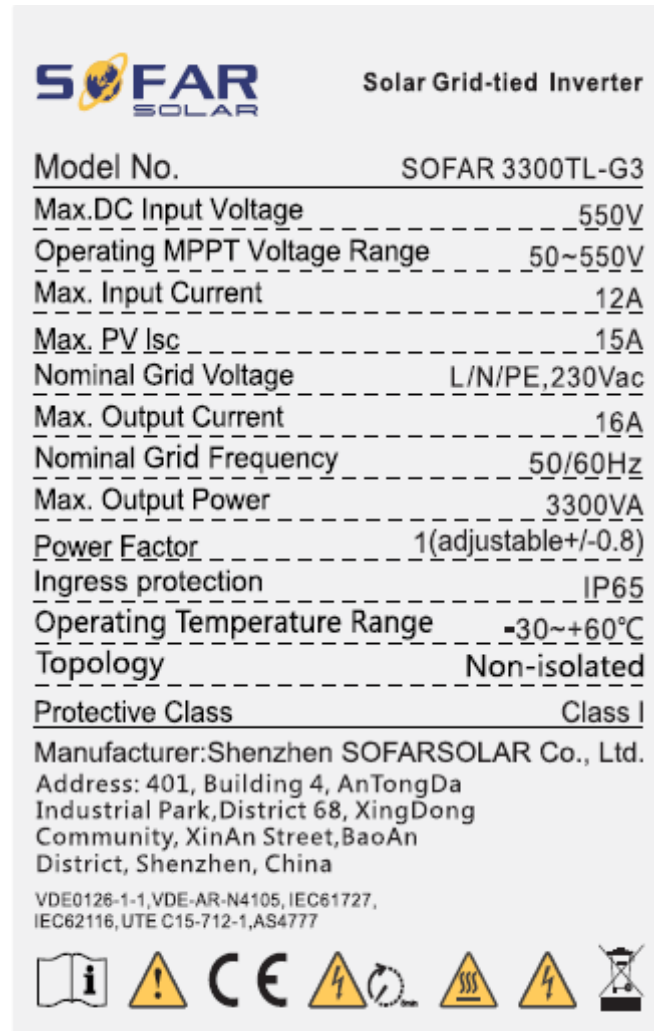
Copy of marking plate(representative):**Note:**

1. The above markings are the minimum requirements required by the safety standard. For the final production samples, the additional markings which do not give rise to misunderstanding may be added.
2. Label is attached on the side surface of enclosure and visible after installation
3. Labels of other models are as the same with SOFAR 3300TL-G3's except the parameters of rating.

Equipment Under Testing:

- SOFAR 3300TL-G3

Variant models:

- SOFAR 3000TL-G3
- SOFAR 2700TL-G3
- SOFAR 2200TL-G3
- SOFAR 1600TL-G3
- SOFAR 1100TL-G3(*)

Model Number	SOFAR 3300TL-G3	SOFAR 3000TL-G3	SOFAR 2700TL-G3	SOFAR 2200TL-G3	SOFAR 1600TL-G3	SOFAR 1100TL-G3
Max. input voltage	550Vd.c.			500Vd.c.		
Max. input current	12Ad.c.	12Ad.c.	12Ad.c.	12Ad.c.	12Ad.c.	12Ad.c.
Operating MPPT voltage range	50-550Vd.c.			50-500Vd.c.		
Full load DC Voltage Range	300-500 Vd.c.	275-500 Vd.c.	250-500 Vd.c.	200-450 Vd.c.	150-450 Vd.c.	110-450 Vd.c.
Rated voltage	360V					
Rated grid voltage	230Va.c.					
Rated grid frequency	50Hz					
Rated output power	3.3kW	3.0kW	2.7kW	2.2kW	1.6kW	1.1kW
Rated output current	13Aa.c.	13 Aa.c.	11.8Aa.c.	9.6Aa.c.	7Aa.c.	4.8Aa.c.
Max. Output Current	16Aa.c.	14.5 Aa.c.	13Aa.c.	10.6Aa.c.	7.7Aa.c.	5.3Aa.c.
Power factor	0.8 leading to 0.8 lagging					
Ambient temperature	-30 °C ~60°C					
Ingress protection	IP65					
Protective class	Class I					

The variants models have been included in this test report without tests because the following features don't change regarding to the tested model:

- Same connection system and hardware topology
- Same control algorithm.
- Output power within 2.5 and 2/3 of the EUT or Modular inverters.
- Same Firmware Version

The results obtained apply only to the particular sample tested that is the subject of the present test report. The most unfavorable result values of the verifications and tests performed are contained herein.

Throughout this report a point (comma) is used as the decimal separator

(*) Model SOFAR 1100TL-G3 is still a variant model with the output current limited to 4.8A per phase, its power output is below 2.5 times the rated power output of the tested model but it has been measured and included on test report 2219 / 0185-C. Therefore, it has been accepted as variant model as well.

2.3 Test equipment list

From	No.	Equipment Name	Model No.	Equipment No.	Calibration Date	Equipment calibration due date
Sofarsolar	1	Digital oscilloscope	DS05014A	MY5007026 6	2019-02-13	2020-02-12
	2	Voltage probe	SI-9110	111541	2019-02-13	2020-02-12
	3	Voltage probe	SI-9110	152627	2019-02-13	2020-02-12
	4	Voltage probe	SI-9110	111134	2019-02-13	2020-02-12
	5	Power analyzer	WT3000	91N610888	2019-02-13	2020-02-12
	6	Current probe	i1000s	29503223	2019-02-13	2020-02-12
	7	Current probe	i1000s	30413448	2019-02-13	2020-02-12
	8	Current probe	CP5150	C150150008	2019-02-13	2020-02-12
	9	Temperature & Humidity meter	TH101B	2010302452 20	2019-02-13	2020-02-12
	10	Temperature & Humidity Chamber	HGTP-225R	HG1303080 1	2019-02-13	2020-02-12
SGS	11	True RMS Multimeter	Fluke / 289C	GZE012-53	2019-02-26	2020-02-25

2.4 Measurement uncertainty

Associated uncertainties through measurements showed in this this report are the maximum allowable uncertainties.

Magnitude	Uncertainty
Voltage measurement uncertainty	±1.5 %
Current measurement uncertainty	±2.0 %
Frequency measurement uncertainty	±0.2 %
Time measurement uncertainty	±0.2 %
Power measurement uncertainty	±2.5 %
Phase Angle	±1°
Temperature	±3° C
Note1: Measurements uncertainties showed in this table are maximum allowable uncertainties. The measurement uncertainties associated with other parameters measured during the tests are in the laboratory at disposal of the solicitant.	

2.5 Test set up of the different standard

The test bench used includes:

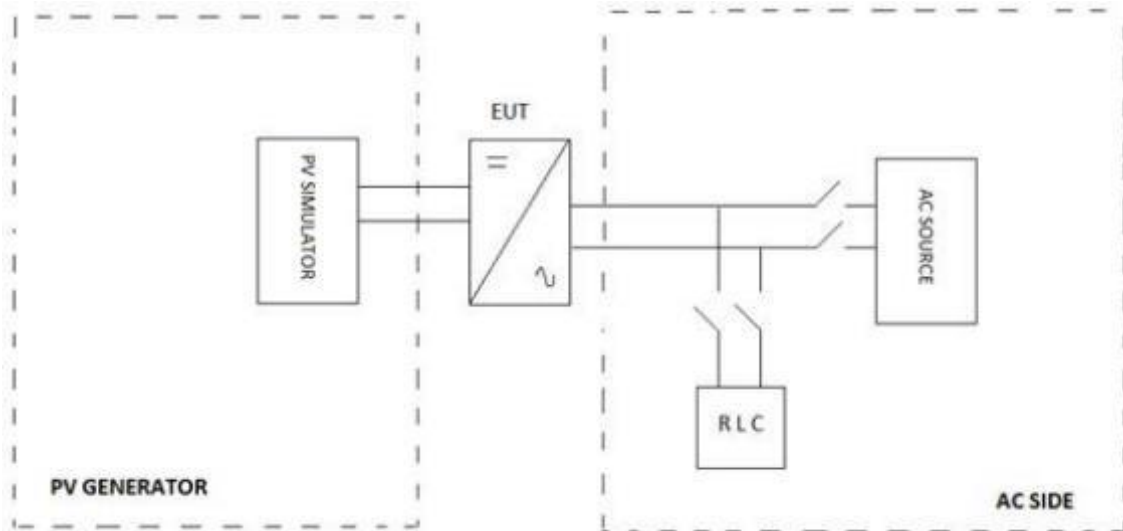

Different equipment has been used to take measures as it shows in chapter 2.3. Current and voltage clamps have been connected to the inverter output for all the tests.

All the tests described in the following pages have used this specified test setup.

2.6 Definitions

EUT	Equipment Under Testing	Hz	Hertz
A	Ampere	V	Volt
VAr	Volt-Ampere reactive	W	Watt
Un	Nominal Voltage	p.u	Per unit
In	Nominal Current	Pn	Nominal Active Power
Ia	Active Current	Qn	Nominal Reactive Power
Ir	Reactive Current	Sn	Nominal Apparent Power
MV	Medium Voltage	°C	Celsius degree
LV	Low Voltage	K	Kelvin degree
RH	Relative Humidity		

3 RESUME OF TEST RESULTS

INTERPRETATION KEYS

- Test object does meet the requirement..... : **P** Pass
- Test object does not meet the requirement : **F** Fails
- Test case does not apply to the test object : **N/A** Not applicable
- To make a reference to a table or an annex..... : See additional sheet
- To indicate that the test has not been realized..... : **N/R** Not realized

TEST AND CHECKS			
Point	Standard	Test procedure	
4.1	IEC 60068-2-1	Test Ae: Cold	P
4.2	IEC 60068-2-2	Test Be: Dry heat.	P
4.3	IEC 60068-2-14	Test Nb: Change of temperature.	P
4.4	IEC 60068-2-30	Test Db: Damp heat, cyclic	P

Note: The declaration of conformity has been evaluated taking account the IEC Guide 115.

4 TEST RESULTS

4.1 TEST AE: COLD

The test purpose is the determination of the aptitude of the components, equipment and other items for use, transport or store at low temperature, according to the standard IEC 60068-2-1. Environmental testing. Part 2-1: Test. Test A: Cold.

Due to the nature of EUT, the applicable Test is Ae: This procedure is applied to specimens heat dissipative which are subjected to low temperature during an enough period for the specimen to reach the thermal stability. The EUT is required to be operating during all test duration.

Test Severities

The specimen is introduced into the chamber which is at the temperature of the laboratory. The temperature is then adjusted to the temperature appropriate to the degree of severity, as specified in the relevant specification. After temperature stability of the test specimen has been reached, the specimen is exposed to these conditions for the specified duration. For specimens that are required to be operational (even though they do not meet the requirements of being heat dissipating), power shall then be applied to the specimen and a functional test is performed as necessary. A further period of stabilization may be necessary and the specimen shall then be exposed to the low temperature conditions for a duration as specified in the relevant specification. Specimens under test are normally in operating conditions.

Test condition:

Test Temperature: -30°C

Test Duration : 16h

Test result:

Measurements Pre-functional test:

PV Input:		AC grid output (line to neutral):	
Voltage DC (V)	360.7	Voltage AC (V)	230.5
Current DC (A)	9.4	Current AC (A)	14.4
Power DC (W)	3390	Active Power AC (W)	3303

Measurements During the test:

PV Input:		AC grid output (line to neutral):	
Voltage DC (V)	348.0	Voltage AC (V)	230.6
Current DC (A)	9.7	Current AC (A)	14.2
Power DC (W)	3372	Active Power AC (W)	3271

Measurements Post-functional test:

PV Input:		AC grid output (line to neutral):	
Voltage DC (V)	358.4	Voltage AC (V)	230.2
Current DC (A)	9.5	Current AC (A)	14.4
Power DC (W)	3391	Active Power AC (W)	3320

Note:5 min average values fill in the table.

After the test, the EUT can operation normally.

4.2 TEST BE: DRY HEAT

The test purpose is the determination of the aptitude of the components, equipment and other items for use, transport or storage at high temperature, according to the standard IEC 60068-2-2. Environmental testing. Part 2-2: Tests. Test B: Dry heat

Due to the nature of EUT applicable test Be: This procedure is applied to specimens heat dissipative which are subjected to high temperature during an enough period time for the specimen to reach the thermal stability. The EUT is required to be operating during all test duration.

Test Severities

The specimen is introduced into the chamber, which is at the temperature of the laboratory. The temperature is then adjusted to the temperature appropriate to the degree of severity as specified in the relevant specification. After temperature stability of the test specimen has been reached, the specimen is exposed to these conditions for the specified duration. For specimens that are required to be operational (even though they do not meet the requirements of being heat dissipating) power shall then be applied to the specimen and a functional test is performed as necessary. A further period of stabilization may be necessary and the specimen shall then be exposed to the high temperature conditions for a duration as specified in the relevant specification. Specimens under test are normally in operating conditions.

Test condition:

Test Temperature: +60°C

Test Duration : 16h

Test result:

Measurements Pre-functional test:

PV Input:		AC grid output (line to neutral):	
Voltage DC (V)	345.9	Voltage AC (V)	231.3
Current DC (A)	9.8	Current AC (A)	14.2
Power DC (W)	3372	Active Power AC (W)	3267

Measurements During test:

PV Input:		AC grid output (line to neutral):	
Voltage DC (V)	346.2	Voltage AC (V)	231.6
Current DC (A)	9.7	Current AC (A)	14.1
Power DC (W)	3372	Active Power AC (W)	3265

Measurements Post-functional test:

PV Input:		AC grid output (line to neutral):	
Voltage DC (V)	347.1	Voltage AC (V)	231.2
Current DC (A)	9.7	Current AC (A)	14.2
Power DC (W)	3377	Active Power AC (W)	3271

Note:5 min average values fill in the table.

After the test, the EUT can operation normally.

4.3 TEST NB: CHANGE OF TEMPERATURE

This test includes alternating periods of high and low temperature with a good definition of transference between both temperatures. The test has been performed according to the standard IEC 60068-2-14. Environmental testing. Part 2-14: Tests. Test N: Change of temperature.

The inverter has been subjected to thermal changes according to the test Nb in order to evaluate the ability of components, equipment or other articles to withstand rapid changes of ambient temperature. With this method, variations of temperature are controlled with a specified speed of change.

The complete test performed includes:

1. Variation from standard atmospheric conditions to the temperature of conditioning "A".
2. Variation from temperature of conditioning "A" to temperature of conditioning "B".
3. Variation from temperature of conditioning "B" to temperature of conditioning "A".
4. Variation from temperature of conditioning "A" to temperature of conditioning "B".
5. Variation from the temperature of conditioning "B" to the ambient temperature of laboratory.

Test Severities

The severity of the test is defined by the combination of the two temperatures, the transfer time, the exposure time of the specimen and the number of cycles.

The lower temperature, T_A , shall be specified in the relevant specification and should be chosen from the test temperatures of IEC 60068-2-1 and IEC 60068-2-2.

The higher temperature, T_B , shall be specified in the relevant specification and should be chosen from the test temperatures of IEC 60068-2-1 and IEC 60068-2-2.

The exposure time, t_1 , of each of the two temperatures depends upon the heat capacity of the specimen. It may be 3 h, 2 h, 1 h, 30 min or 10 min, or as specified in the relevant specification. Where no exposure period is specified in the relevant specification, it is understood to be 3 h. The preferred number of test cycles is five, unless otherwise specified in the relevant specification.

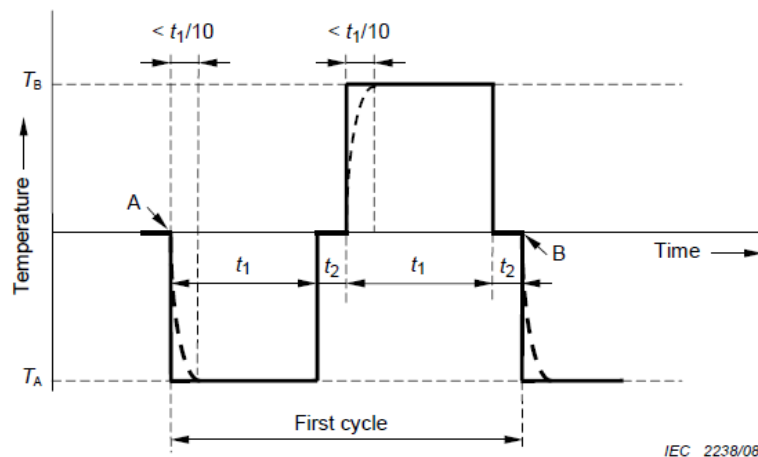

Key

- A start of first cycle
- B end of first cycle and start of second cycle

NOTE The dotted curve is explained above.

Figure 2 – Na test cycle

Test condition:

Low temperature T_A: -25 °C
 High temperature T_B: +60 °C
 Duration of exposure time t₁: 3h
 Duration of transfer time t₂: 3min
 Number of cycles: 5
 Recovery: 2h

Test result:

Measurements Pre-functional test:

PV Input:		AC grid output (line to neutral):	
Voltage DC (V)	367.8	Voltage AC (V)	233.5
Current DC (A)	9.3	Current AC (A)	14.2
Power DC (W)	3392	Active Power AC (W)	3304

Measurements During test:

PV Input:		AC grid output (line to neutral):	
Voltage DC (V)	367.6	Voltage AC (V)	233.8
Current DC (A)	9.3	Current AC (A)	14.2
Power DC (W)	3393	Active Power AC (W)	3305

Measurements Post-functional test:

PV Input:		AC grid output (line to neutral):	
Voltage DC (V)	367.5	Voltage AC (V)	233.8
Current DC (A)	9.3	Current AC (A)	14.2
Power DC (W)	3394	Active Power AC (W)	3304.9

Note: 5 min average values fill in the table.

After the test, the EUT can operation normally.

4.4 TEST DB: DAMP HEAT, CYCLIC (12 H + 12 H)

The test purpose is the determination of the suitability of components, equipment or other articles for the use, transportation and storage abnormal conditions of high humidity, combined with cyclic temperature changes and, in general, producing condensation on the surface of the specimen, according to the standard IEC 60068-2-30. Environmental testing. Part 2-30: Tests. Test Db-Variant 1: Damp heat, Cyclic (12 h + 12 h).

Test Severities

Variant 2 (see Figure 2b)

The temperature shall be lowered to 25 °C ± 3 K within 3 h to 6 h, but without the additional requirement for the first hour and one half as in variant 1. The relative humidity shall be not less than 80 % RH.

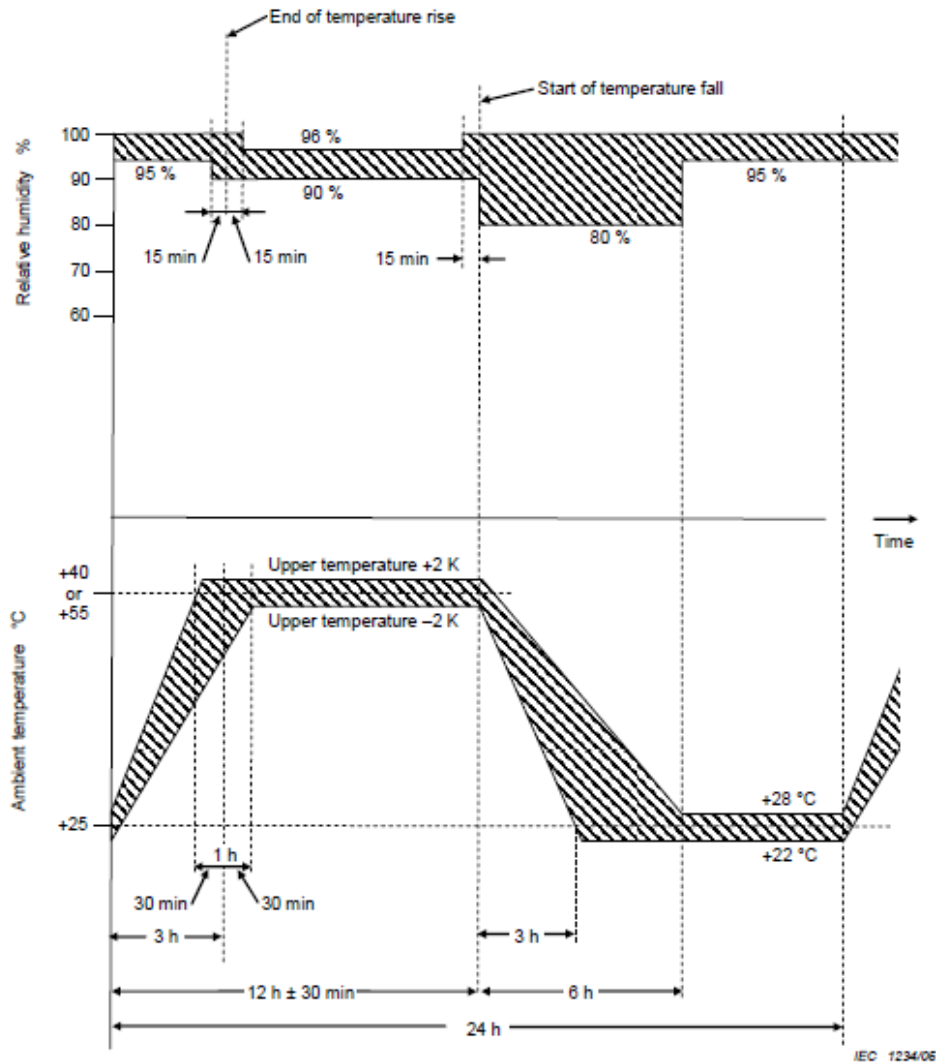

Figure 2b – Test Db – Test cycle – Variant 2

Test condition:

Test Db, variant 2, b-cycle
 The humidity level shall be 95 % ± 5 %
 A minimum number of 3 cycles
 Lower temperature: 25°C
 Upper temperature: 55°C

Test result:

Measurements Pre-functional test:

PV Input:		AC grid output (line to neutral):	
Voltage DC (V)	367.4	Voltage AC (V)	233.7
Current DC (A)	9.3	Current AC (A)	14.2
Power DC (W)	3394	Active Power AC (W)	3305

Measurements During test:

PV Input:		AC grid output (line to neutral):	
Voltage DC (V)	367.5	Voltage AC (V)	234.1
Current DC (A)	9.3	Current AC (A)	14.1
Power DC (W)	3394	Active Power AC (W)	3305

Measurements Post-functional test:

PV Input:		AC grid output (line to neutral):	
Voltage DC (V)	367.4	Voltage AC (V)	234
Current DC (A)	9.3	Current AC (A)	14.1
Power DC (W)	3395	Active Power AC (W)	3305

Note:5 min average values fill in the table.
 After the test, the EUT can operation normally.

5 PICTURES

Front view 1 (SOFAR 2700TL-G3, SOFAR 3000TL-G3, SOFAR 3300TL-G3)



Back view 1 (SOFAR 2700TL-G3, SOFAR 3000TL-G3, SOFAR 3300TL-G3)

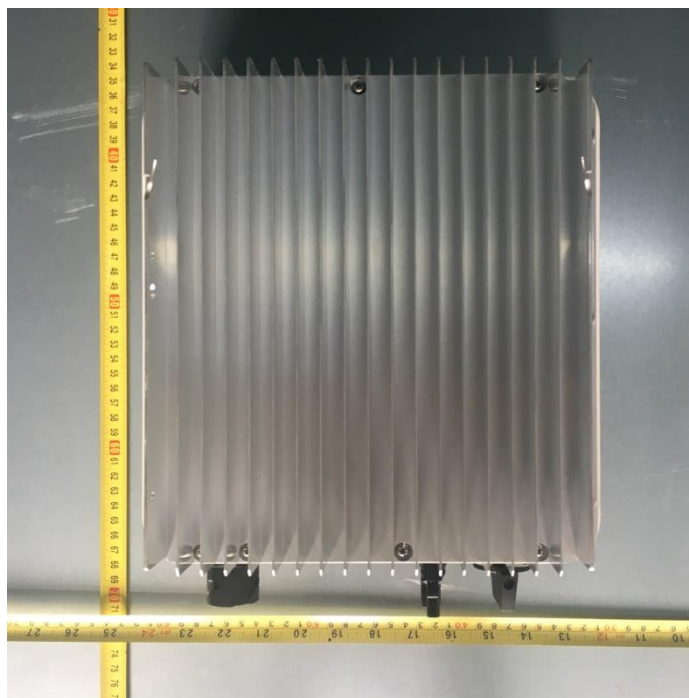

Front view 2 (SOFAR 1100TL-G3, SOFAR 1600TL-G3, SOFAR 2200TL-G3)



Back view 2 (SOFAR 1100TL-G3, SOFAR 1600TL-G3, SOFAR 2200TL-G3)



Side View (SOFAR 2700TL-G3, SOFAR 3000TL-G3, SOFAR 3300TL-G3)

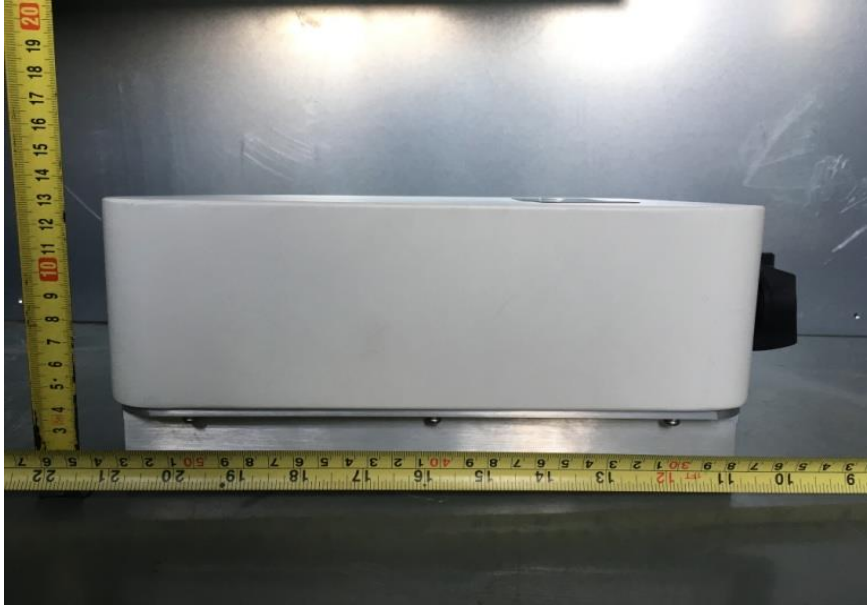

Side View (SOFAR 1100TL-G3, SOFAR 1600TL-G3, SOFAR 2200TL-G3)

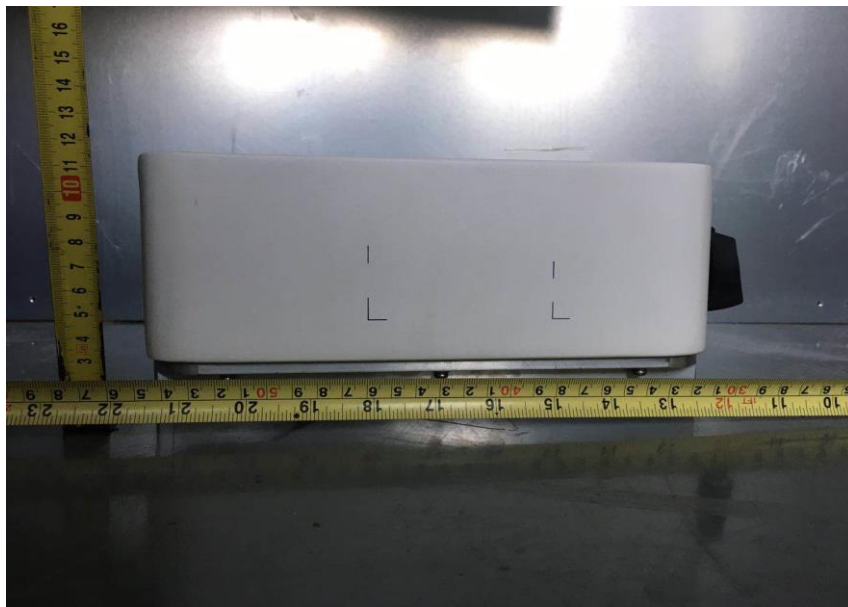

Internal view of enclosure (SOFAR 2700TL-G3, SOFAR 3000TL-G3, SOFAR 3300TL-G3)

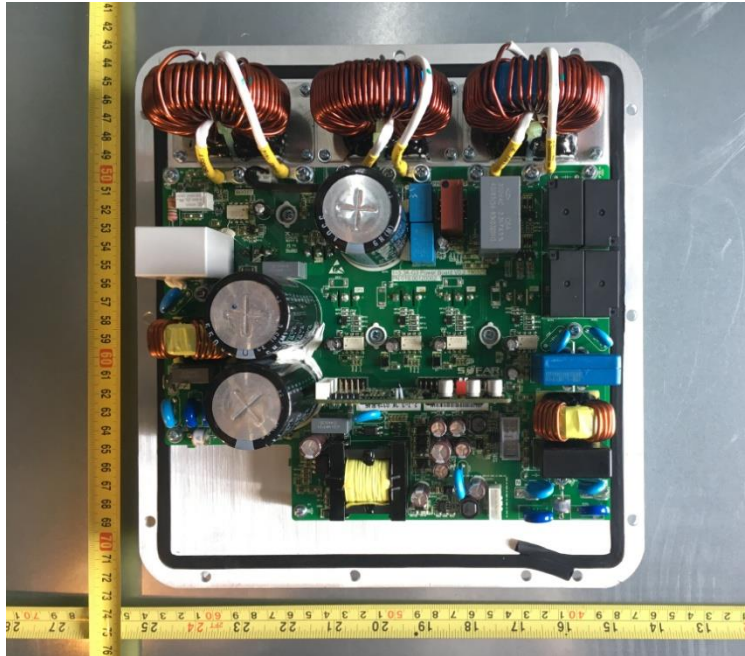

Internal view of enclosure (SOFAR 1100TL-G3, SOFAR 1600TL-G3, SOFAR 2200TL-G3)

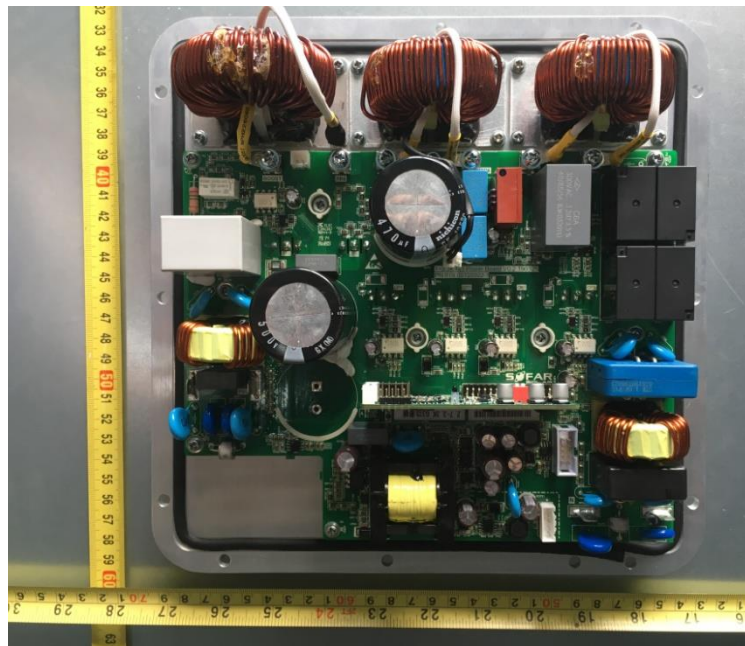

Front side of main board 1 (SOFAR 2700TL-G3, SOFAR 3000TL-G3, SOFAR 3300TL-G3)

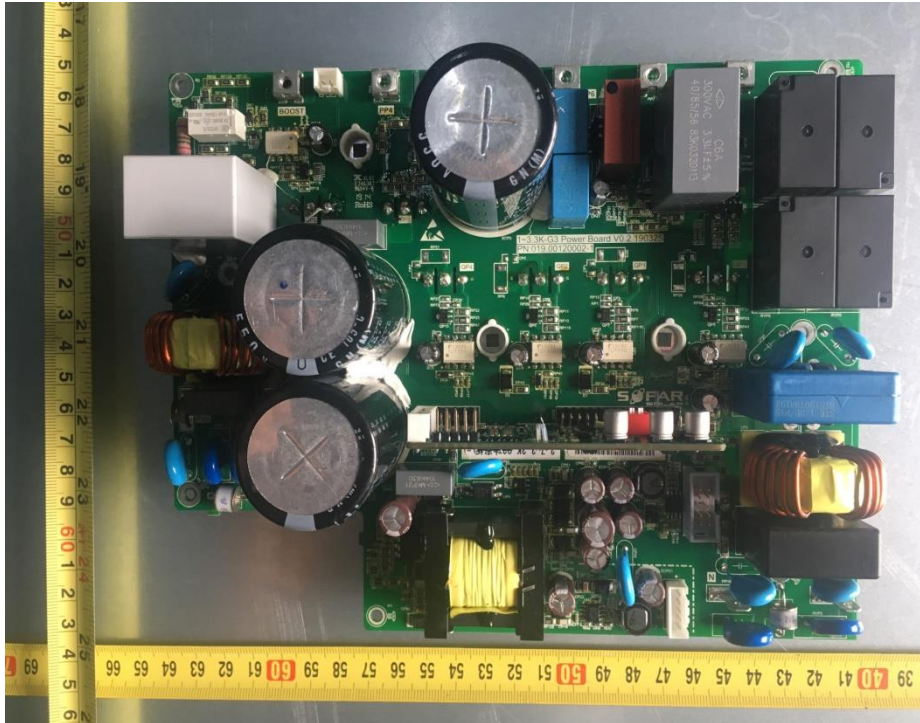

Back side of main board 1(SOFAR 2700TL-G3, SOFAR 3000TL-G3, SOFAR 3300TL-G3)

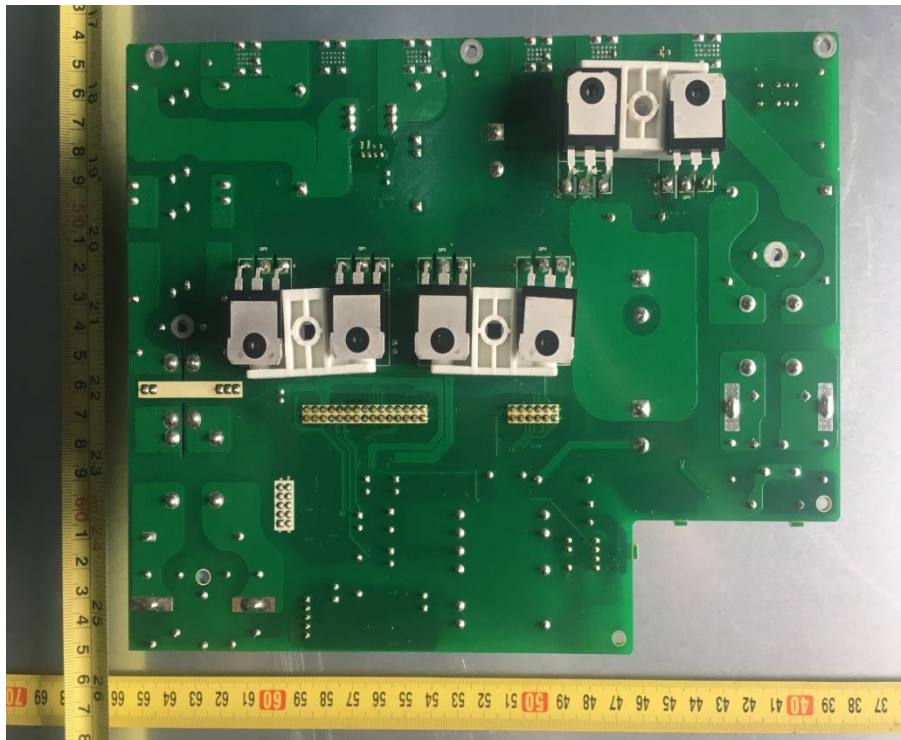

Front side of main board 2 (SOFAR 1100TL-G3、SOFAR 1600TL-G3、SOFAR 2200TL-G3)

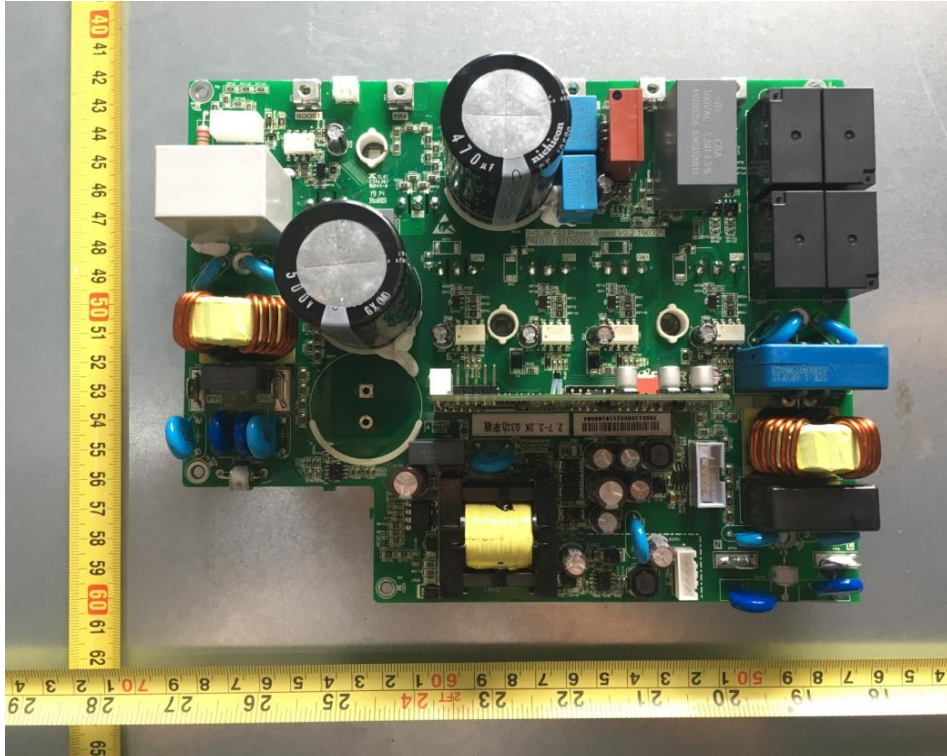

Back side of main board (SOFAR 1100TL-G3、SOFAR 1600TL-G3、SOFAR 2200TL-G3)

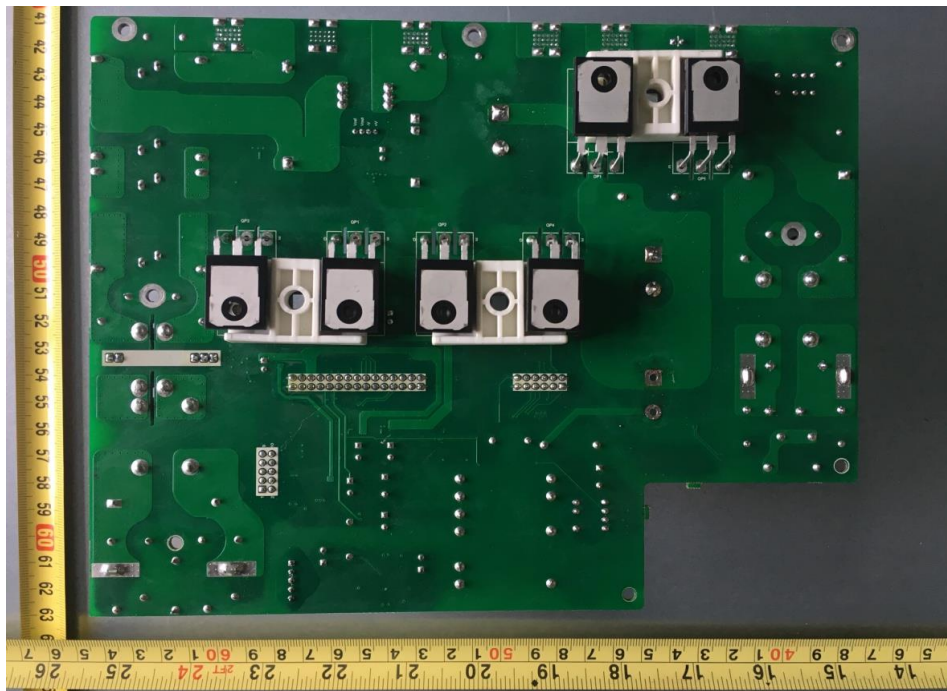

Front side of Control board

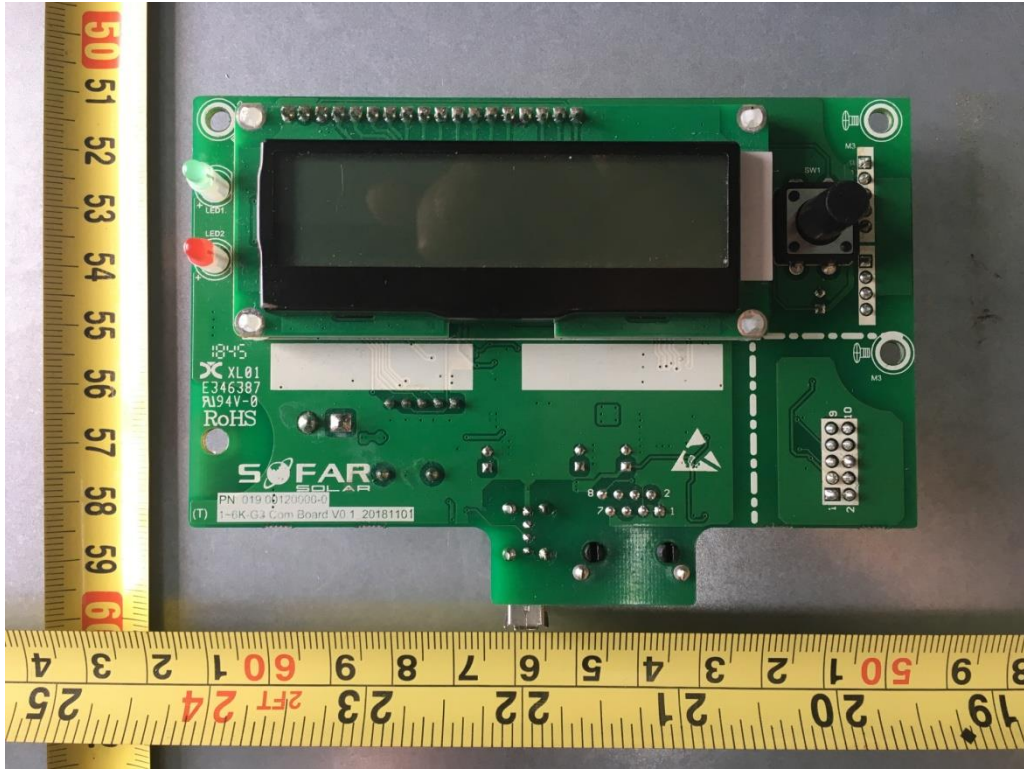

Front side of Control board

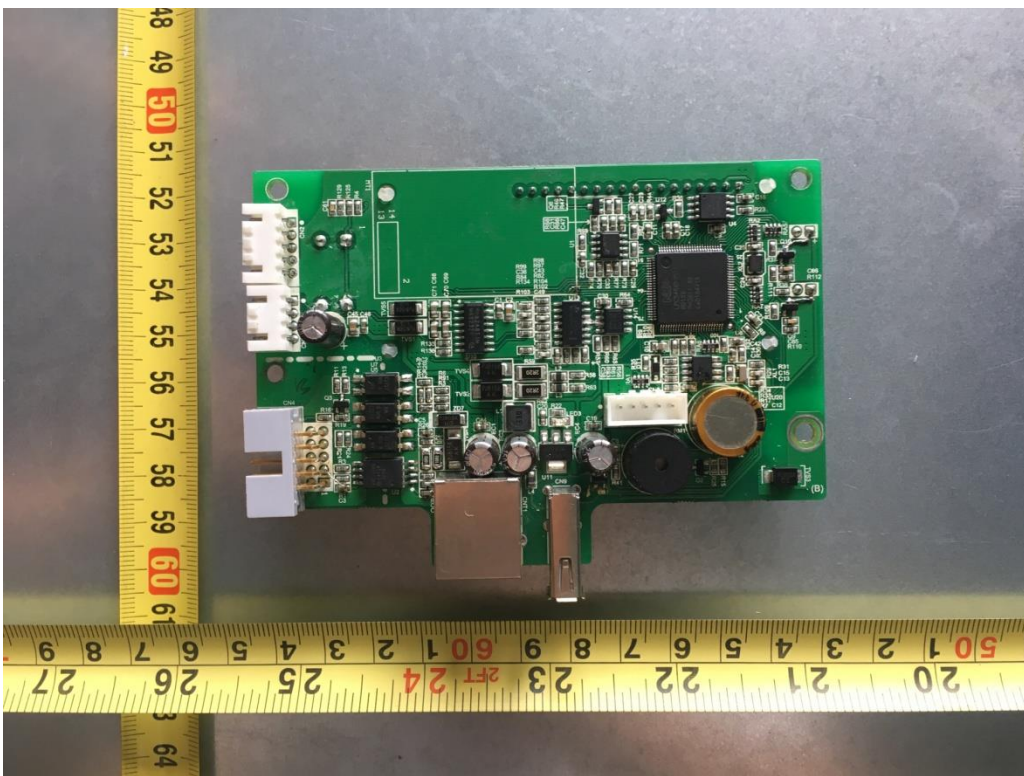

Front view of RS 232 board

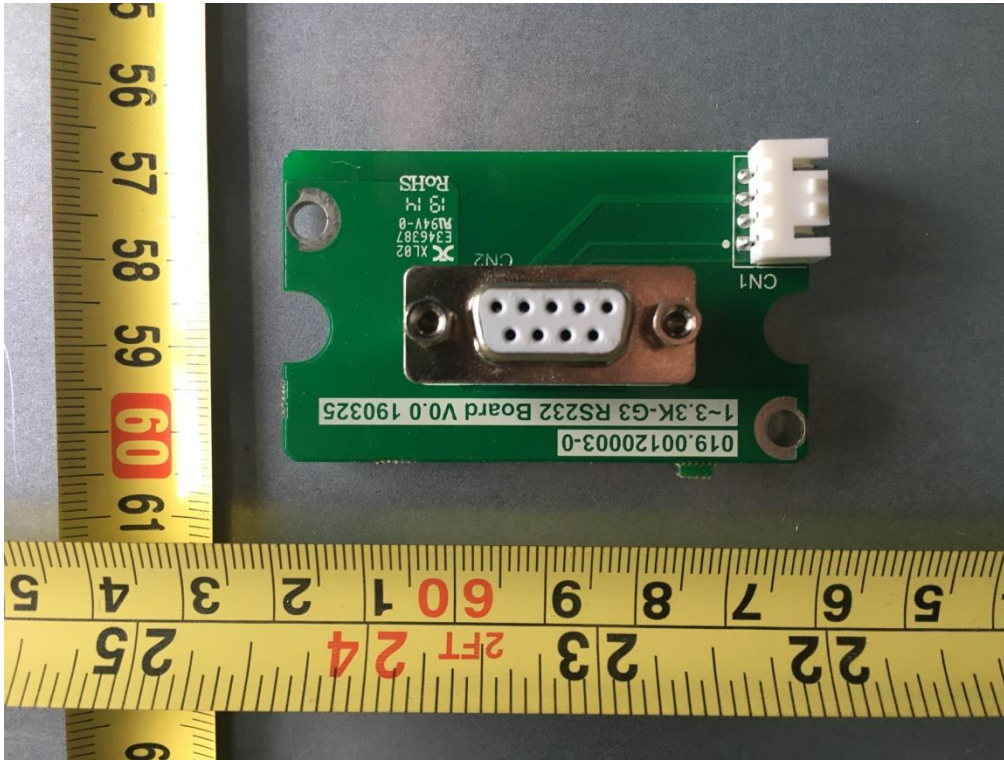

Back view of RS 232 board

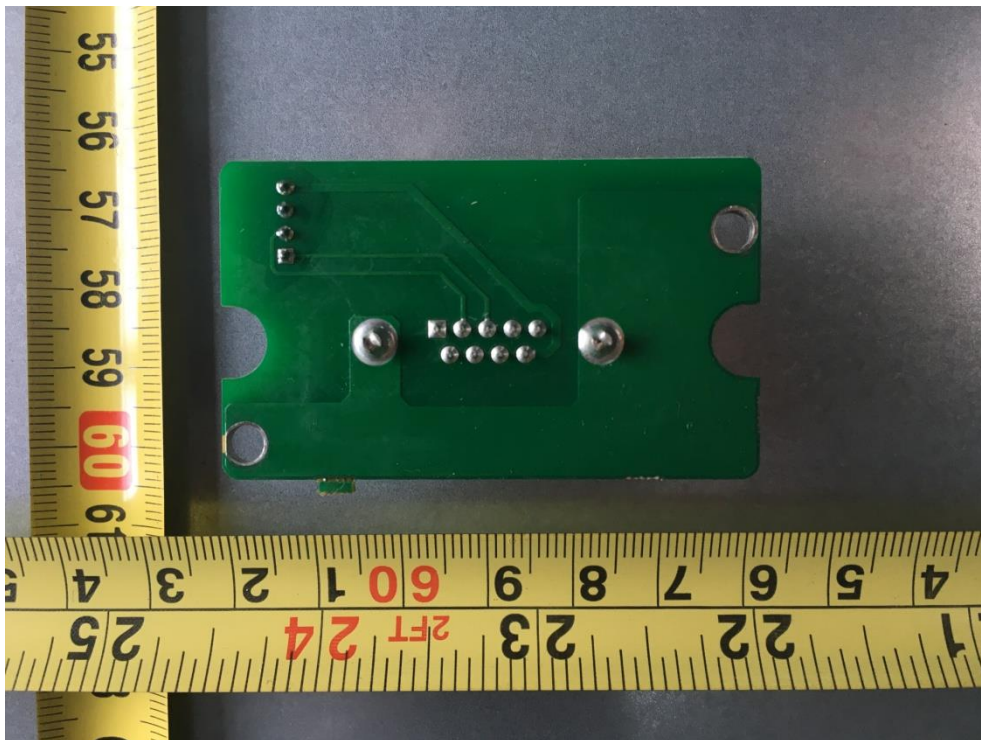

DC&AC Terminals



Grounding

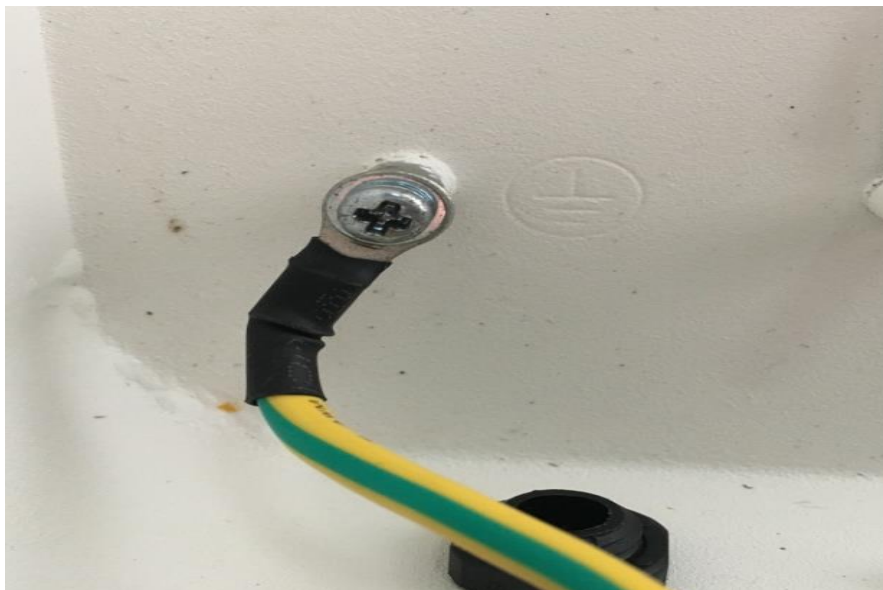

IEC 60068-2-1 / IEC 60068-2-2 / IEC 60068-2-14 / IEC 60068-2-30

Software Number (SOFAR 2700TL-G3, SOFAR 3000TL-G3, SOFAR 3300TL-G3)



Software Number (SOFAR 1100TL-G3, SOFAR 1600TL-G3, SOFAR 2200TL-G3)

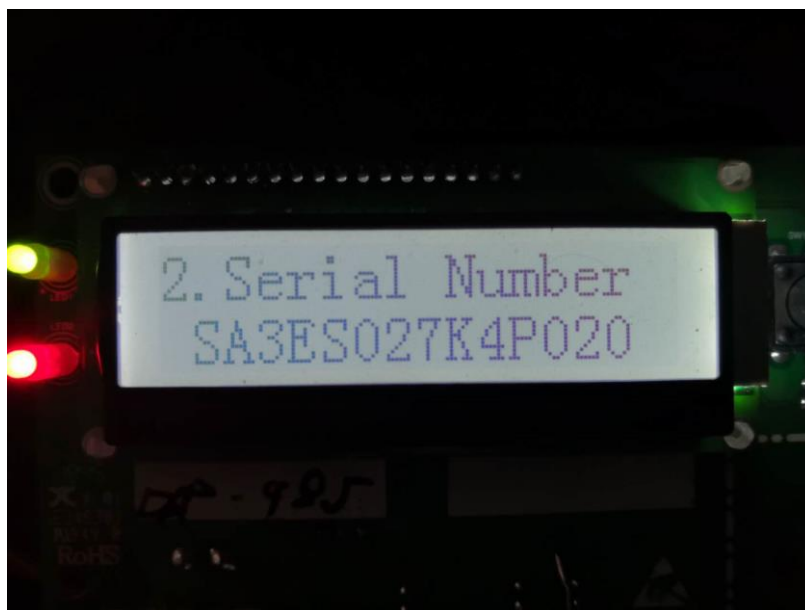

Serial version



6 ELECTRICAL SCHEMES

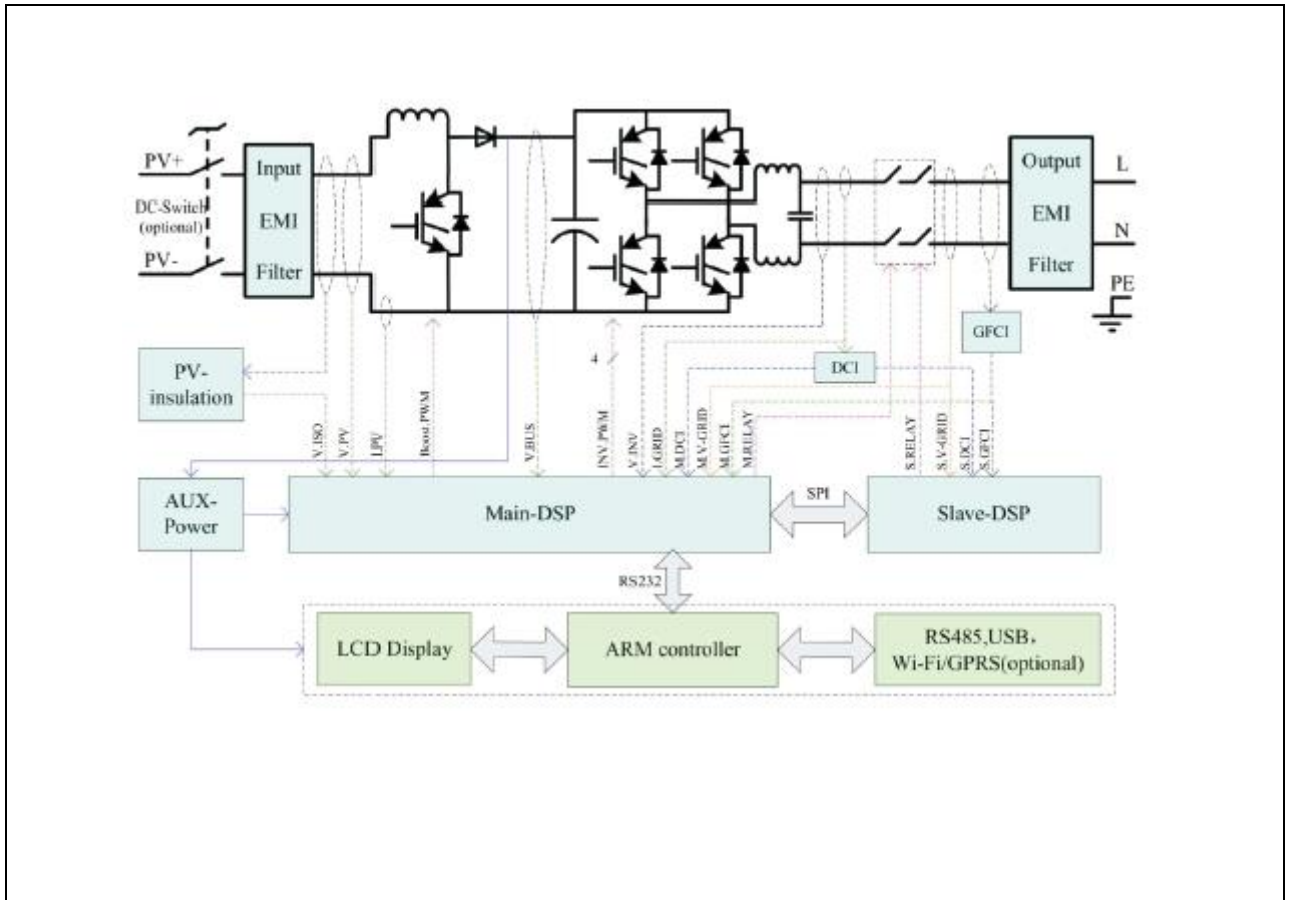

-----END OF REPORT-----